

TEQ-Home

Quick Start Guide

Please create you SOFIHUB portal account before beginning set up.

1. Setting up your TEQ-Home

Turn the device on and attach the included aerial to the back of the unit, this will be inside the box under the first layer of sensors. After a few moments the device will greet you with a welcome chime indicating that the device is now ready to be set up.

2. Create a portal account and link your device

You can access the **SOFIHUB portal** through the “portal” tab on the menu of the SOFIHUB website: **sofihub.com**

Please select your location

Australia/New Zealand Portal OR United States/Canada Portal



To create your **SOFIHUB portal** account:
Click “Create Account” and follow the prompts to link your device to the portal.

A screenshot of the SOFIHUB login page. It features the SOFIHUB logo at the top. Below the logo are two input fields: "Email Address" and "Password". There is a "Remember me" checkbox and a "Forgot Password" link. A blue "Log in" button is positioned to the right of the password field. Below these elements is a link that says "Don't have an account yet?" and a large blue "Create Account" button. A blue arrow points from the "Create Account" button to the next screenshot.A screenshot of the SOFIHUB account creation page. It features the SOFIHUB logo at the top. Below the logo is the heading "Create an account" and the text "Tell us a bit about yourself...". There are several input fields: "First name", "Last name", "Email", "Mobile" (with a country code dropdown), "Password", and "Confirm". Each field has a red asterisk indicating it is required. At the bottom, there is a reCAPTCHA widget with the text "protected by reCAPTCHA" and "Privacy Terms". Below the reCAPTCHA are "Back" and "Create Account" buttons.

What are you claiming?

×

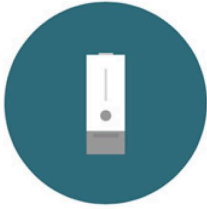

TEQ-Home
(For use inside the home)



eazense
(For use inside the home)



TEQ-Secure
(For use outside the home)

3. Subscribe to monthly monitoring fee

Whoops, we're missing your payment details!

A subscription is needed to use your SOFIHUB . We need a payment method for the subscription.

You cannot use your SOFIHUB without a valid subscription and valid payment method.

Please add your payment details below to start your subscription.

Card number MM / YY CVC

Verify Card

Verifying your card does not charge your card or start subscription. Once your card is verified the next screen will ask you to confirm before we charge your card.

One device = \$20.00 per month. This covers usage of the included sim card and all online portal access.

4. Activating the sensors

Remove the cover from the back of the sensor, hold the batteries in place and remove the plastic tab. Place the cover back on and set the sensor down next to the hub. Repeat for all sensors. A light will appear on the front of the sensor indicating that it is in working order.

4.1. Turn on Occupancy Mode

Through the portal, turn on occupancy mode (for testing).

This can be found under **Settings** in the **Advanced** Tab.

The hub will announce when it detects movement in a room.

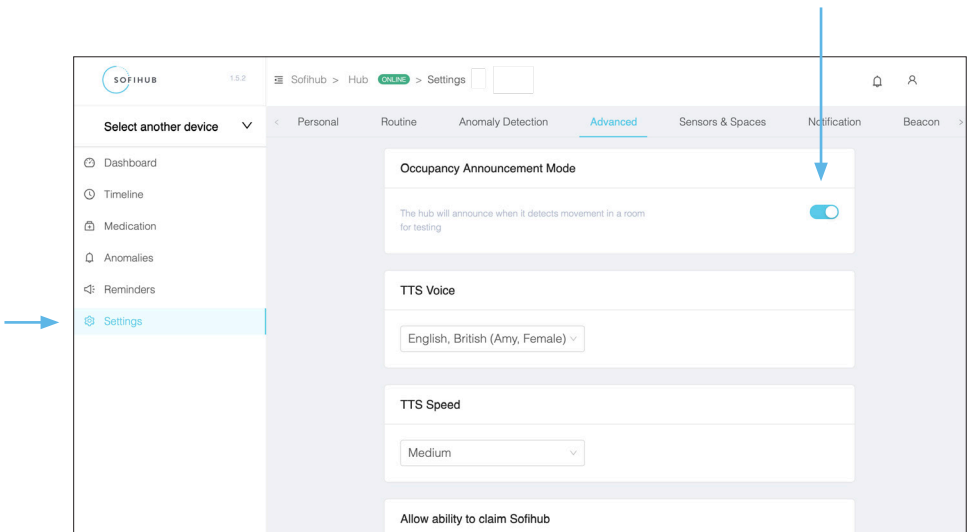

5. Installing and testing the sensors

It is important that the positioning of the sensors are carefully considered and correctly placed in the occupant's home.

The sensors come with covers to ensure that there is no unwanted triggering of the sensors.

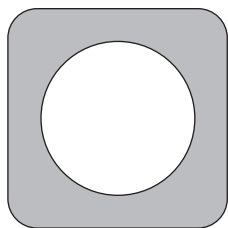

UNCOVERED

(motion)

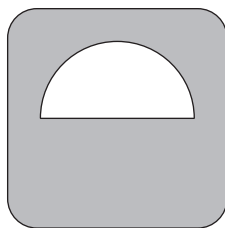

PET COVER

(motion)

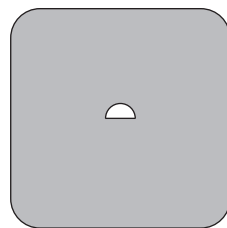

TRANSIT COVER

(transit)



Sensor trigger area

Please note that the illustrations are not to scale and is simply a visual demonstration of the sensor placement and covers in effect.

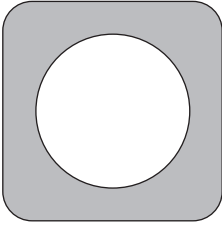

Ensure that the sensors are placed facing away from any windows as bright lights can trigger the sensors.

UNCOVERED

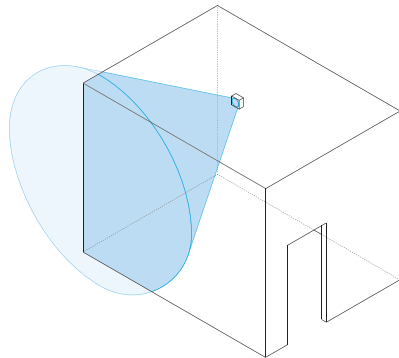
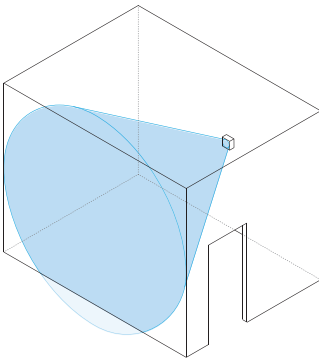
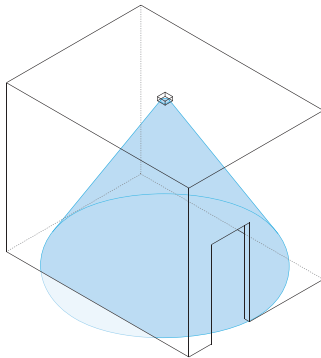

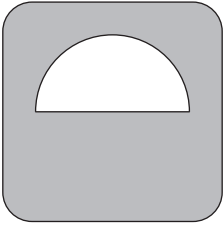

PET COVER

If the occupant has pets, this cover will ensure that they will not trigger the sensors.

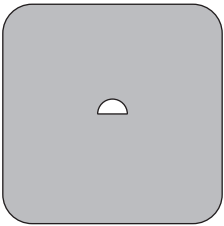
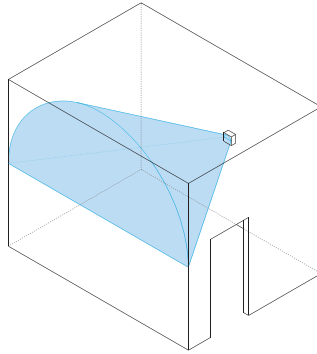

TRANSIT COVER

Transit sensors are located in doorways and should only trigger when someone walks through the doorway

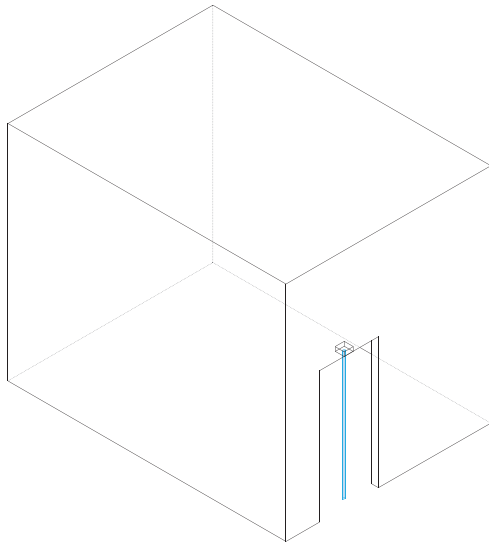

6. Sensors and spaces

Settings > Sensors & Spaces

This is where you can see all your current sensors and the spaces (or rooms) they are located within the home. You can add new sensors and allocate them to rooms, replace them, or delete them.

A sensor must be allocated to a space.

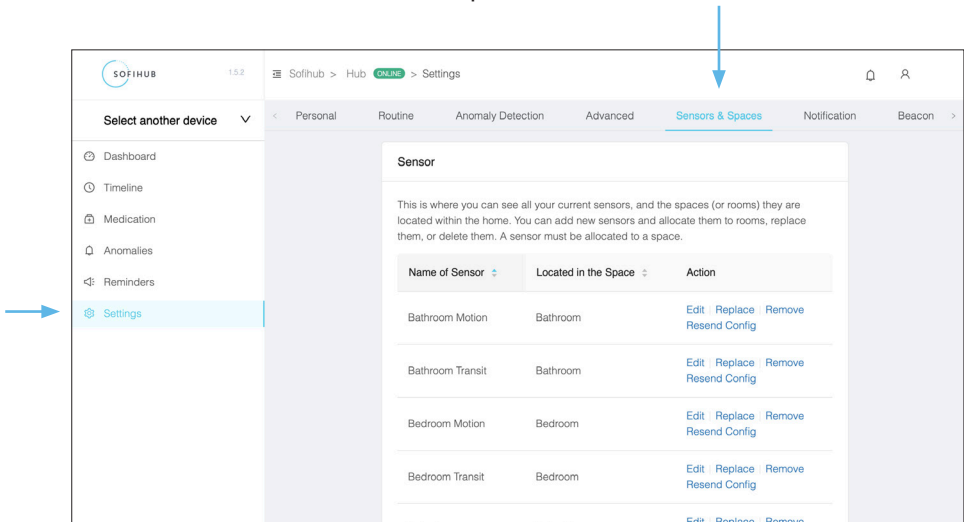

7. Complete testing

Once your device and sensors are optimally placed, turn **OFF** occupancy mode

Settings > Advanced



8. Adding carers

You can securely invite carers to access the SOFIHUB portal through the **carers** tab in the **menu settings**

+ Invite Carer

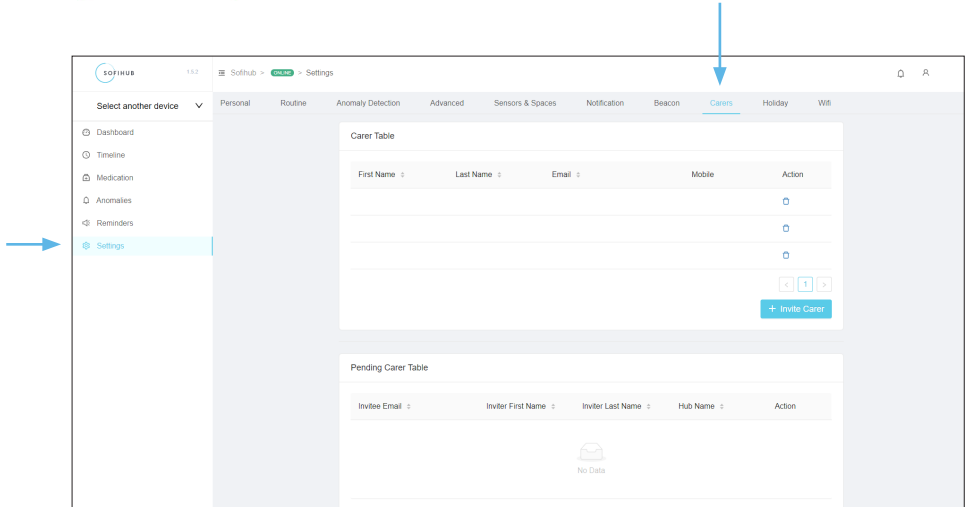

Invite a new carer

In order to invite a new carer you will need to provide their exact email address. If the user is already registered they will be notified about your invitation, if they have not registered yet, they will be invited to register. Please type in the new carer's email address:

After the invite is sent, it will expire after 7 days if no action is taken. You can view pending invites at any time in the "Invited Carers" tab.

protected by reCAPTCHA
[Privacy](#) [Terms](#)

Cancel Invite

9. Your SOFIHUB Portal

9.1. Dashboard

Overview of the status of your device, the sensors, recent messages and recent occupancies.

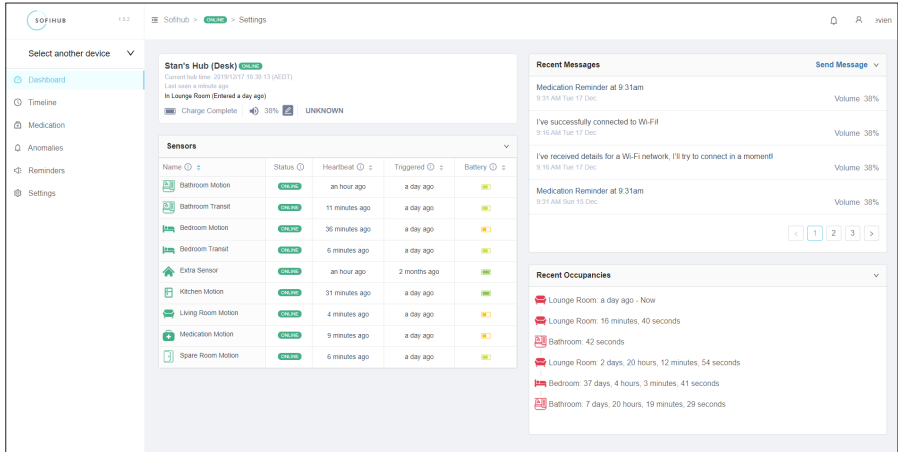

9.2. Timeline

Visual timeline of occupancies

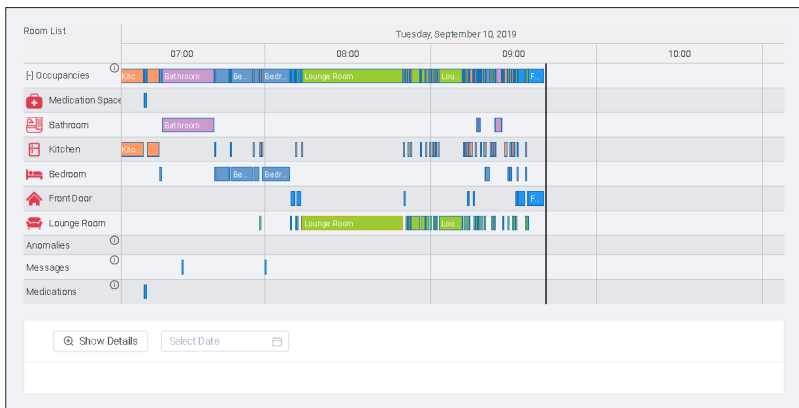

9.3. Medication

View medication access

9.4. Anomalies

View anomalies (past, recent and current). eg. Late to bed, late to wake, bathroom too long

9.5. Reminders

View and add reminders

Name	Message	Date	Time	Days	Action
Charge your Beacon (weekday reminder)	Hi there, don't forget to put your beacon on charge before you go to bed tonight!	27/11/2019	10:00 PM	Mon,Tue,Wed,Thu,Fri	🗑️

The image shows a user interface for managing reminders. At the top, there are navigation buttons: a left arrow, a box containing the number '1', a box containing the number '2', and a right arrow. Below these is a blue button with a white plus sign and the text '+ Add Reminder' followed by a downward arrow. A dropdown menu is open below the button, listing three options: 'Time Based Reminder', 'Medication Reminder', and 'Occupancy Based Reminder'.



Phone: 1300 110 366
Email: info@sofihub.com

SOFIHUB.COM